

#### Main applications

- Plastics extrusion lines and injection moulding machines
- Polymerisation plant for synthetic fibre production
- Climatic chambers and test benches
- Continuous ovens and drying unit ceramics and bricks
- Chemical and pharmaceutical industries
- Furnaces
- Food processing plant
- Painting machines
- Water treatment
- Siderurgy industry
- Packaging machinery



#### Main features

- Universal input configurable from the faceplate
- Acquisition of the input signal every 120msec ; resolution 30000steps
- Two control outputs: relay, logic or analogue with Heat/Cool function
- 3 configurable alarms
- 2 analogue outputs (setpoint retransmission)
- 2 digital inputs with configurable function
- Auxiliary input for C.T. or remote setpoint
- Heater Break or shortcircuit probe alarm
- Self and Auto-tuning, Soft-start, Local/Remote setpoint, Auto/Man
- 12 (16) steps arranged in max. 4 programs
- Second SP retransmitted to a slave controller, with same time-base

#### GENERAL

Microprocessor setpoint programmer and controller, format 48x96 / 96x96 (1/8 DIN - 1/4 DIN).

Manufactured using SMT, the instrument provides a complete operator interface, protected by a Lexan membrane that ensures level IP65 faceplate protection. It has 4 keys, two green LED displays, each with 4 digits, 4 red indicating LED's for the 4 logic or relay outputs, and a further 3 LED's that are programmable to indicate the various operational states of the instrument.

10 led red bargraph indication can be associated with analogue outputs for control, inputs or deviations.

The main input for the process variable is universal and provides the possibility to connect many types of input sensor: thermocouple, resistance thermometer, thermistor, linear inputs, potentiometer, all with the possibility of custom linearisation that can be defined using the faceplate keys. The type of input is selected from the faceplate keys and no external shunts or adapter are required.

A second auxiliary isolated analogue input is available, which can also be configured for a linear input, potentiometer or current transformer. There are two isolated digital inputs for entering the program commands of start,

stop and reset, choosing the program and to step through the program.

The instrument can have up to 4 relay (5A/250V) or logic (11Vdc, 20mA) outputs and up to 2 isolated analogue outputs in voltage or current.

The function of each output is configurable and event outputs linked to the individual program step as well as control and alarm functions can be provided.

A further isolated output (10 or 24Vdc, 30mA max.) is available for powering external transmitters or potentiometers.

The serial communication interface RS485 (RS232C compatible) makes it possible to read or modify any parameter and to govern the instrument online (local/remote manual/automatic commutation, internal timer control, direct control of outputs).

Protocols available: MODBUS RTU and CENCAL (Gefran).

The sequence for setting up the programmer is particularly brief and there are up to 8 steps, each with a setpoint ramp and hold.

It is also easy to set up any interlocks required from logic inputs and the event outputs, as well as the type of restart preferred using the few set-up steps in the "Step" menu.

The various steps can be regrouped in 4

different programs.

All the programming procedures of the instrument are facilitated by the grouping of the parameters in function blocks (**CFG** for the control parameters, **Inp** for the inputs, **Out** for the outputs, etc.) and by the possibility of selecting a simplified menu for entering the most frequently used parameters.

The instrument can also select the parameters it needs to display as a function of the hardware configuration, automatically concealing those that are not influential.

To simplify the configuration even further, a programming kit is available for PC, which includes a menu driven configuration program for Windows and the necessary cable to connect the instrument (see data sheet cod. WINSTRUM).

The programmer, as well as executing the program controlling the main output (heat/cool with two independent PID loops), can also retransmit 2 different setpoint profiles, with a common time base, to a slave controller using the two analogue outputs.

In the execution phase of the programmer, the two displays are used to monitor the behaviour of the program and make any necessary adjustments immediately.

## TECHNICAL DATA

### INPUTS

Accuracy 0,2% f.s.  $\pm 1$  digit.  
 Acquisition of the input signal 120msec.  
 Decimal point position for linear groups can be set freely.  
 For inputs from TC, RTD, PTC a decimal figure in the maximum display field (-199,9...999,9).

### TC - Thermocouples

**J** (Fe-CuNi) 0...1000°C / 32...1832°F  
**K** (NiCr-Ni) 0...1300°C / 32...2372°F  
**R** (Pt13Rh-Pt) 0...1750°C / 32...3182°F  
**S** (Pt10Rh-Pt) 0...1750°C / 32...3182°F  
**T** (Cu-CuNi) -200...400°C / -328...752°F  
**B** (Pt30Rh-Pt6Rh) 44...1800°C / 111...3272°F  
**E** (NiCr-CuNi) -100...750°C / -148...1382°F  
**N** (NiCrSi-NiSi) 0...1300°C / 32...2372°F  
**(Ni-Ni18Mo)** 0...1100°C / 32...2012°F  
**L-GOST** (NiCr-CuNi) 0...600°C / 32...1112°F  
**Custom** -1999...9999

### RTD 3-wires

Pt100 -200...850°C / -328...1562°F  
 JPt100 (JIS C 1609/81)  
 -200...600°C / -328...1112°F  
**Custom** -1999...9999

### PTC

(alternative to RTD)  
 -55...120°C / -67...248°F  
**Custom** -1999...9999

### DC - Linear

0...50mV; 10...50mV; 0...20mA  
 4...20mA; 0...10V; 2...10V  
 Custom linearisation with 32 segment

### Auxiliary input

insulation 1500V  
 For remote setpoint:  
 (0...10V, 2...10V, Ri=1M $\Omega$ )  
 (0...20mA, 4...20mA, Ri=5 $\Omega$ )  
 potentiometer > 500 $\Omega$   
 For current transformer:  
 CT 50mAac, 50/60Hz, Ri=1,5 $\Omega$

### Logic

Insulation 1500V  
 NPN 24V/4,5mA (PNP 24V/3,6mA)  
 Configurable function: Man/Auto,  
 Loc/Rem, Alarms Reset, Hold,  
 Setpoint selection.

### OUTPUTS

Outputs fully configurable for:  
 single alarm, "OR" or "AND" of multiple  
 alarms, logic input repetition.

### Relay

With rating: 5A/250V,  $\cos\phi=1$   
 (order code R)

### Logic

11Vdc, Rout=220 $\Omega$ .=(20mA, max.6V)  
 (order code D)

### Analogue retransmission

isolated 1500V  
 - Up to 2 analogue outputs for control or  
 retransmission (input signal, setpoint,  
 auxiliary input, alarm setpoint).  
 - Scale range selectable from keyboard.  
 - Configurable output 0...10Vdc;  
 0...20/4...20mA  
 - Resolution 4000 steps

### SERIAL LINE

Optoisolated 4-wires  
 Passive Current Loop configurable (1200  
 baud) interface, RS232 and RS422/485  
 (1200, 2400, 4800, 9600, 19200 baud).  
 Protocol: GEFTRAN CENCAL or MODBUS

### POWER SUPPLY

Standard: 100 to 240Vac/dc  $\pm 10\%$   
 on request: 20 to 27Vac/dc  $\pm 10\%$   
 50/60Hz; 12VAmax.  
 Protection by internal fuse not serviceable  
 by the user

### Transmitter Supply

isolated 1500V  
 10/24Vdc max. 30mA short circuit protec-  
 tion

### AMBIENT CONDITION

**Working temperature range:** 0...50°C  
**Storage temperature range:** -20...70°C  
**Humidity:** 20...85%Ur non condensing

### Control

Cooling setpoint relative to Heating set-  
 point  
 On/Off, P, PD, PID for heating and cool-  
 ing with configurable parameters.  
 • Proportional band 0,0...999,9% f.s.  
 • Integral time 0,0...999,9 min  
 • Derivative time 0,0...99,99 min  
 • Max and min control output power  
 limitation: 0,0...100,0%  
 • Manual Reset -999...999 digit  
 • Power Reset -100,0...100,0%  
 • Cycle time 0,1...200sec  
 • Soft-start 0,0...500,0 min

### Alarms

- Up to 3 alarms, settable as absolute,  
 deviation or symmetrical deviation alarm  
 with respect to the control setpoint with  
 configurable function (Hi or Lo).  
 - The alarm point may be set anywhere  
 within the configured scale.  
 - Heater Break Alarm  
 - Loop Break Alarm  
 - Alarm Hysteresis configurable  
 - Alarms can be assigned to main input,  
 auxiliary input or control SP.

### WEIGHT

400g (1600P); 600g (1800P) in complete  
 version

## FACEPLATE DESCRIPTION

- A - PV Display: process variable
- B - SV Display: setpoint value
- C - "Function" key
- D - "Lower" key
- E - "Raise" key
- F - "Automatic/Manual" selection
- G - Function indication
- H - Indication of active outputs

Double green LED display (4 Digit)  
 Faceplate protection IP65

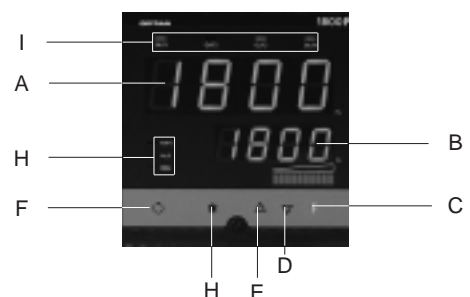
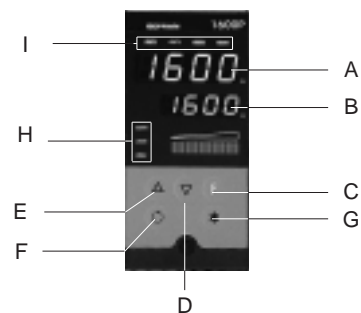

## DIMENSIONS AND CUT OUT

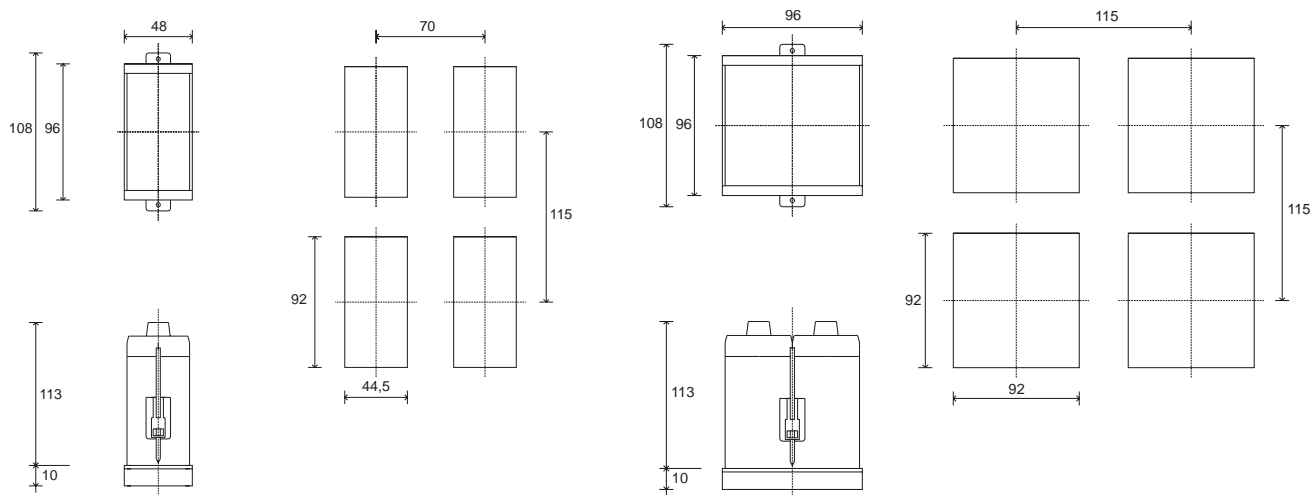

Dimensions: 48x96mm - 96x96mm (1/8DIN - 1/4DIN) depth 113mm

## CONNECTION DIAGRAM

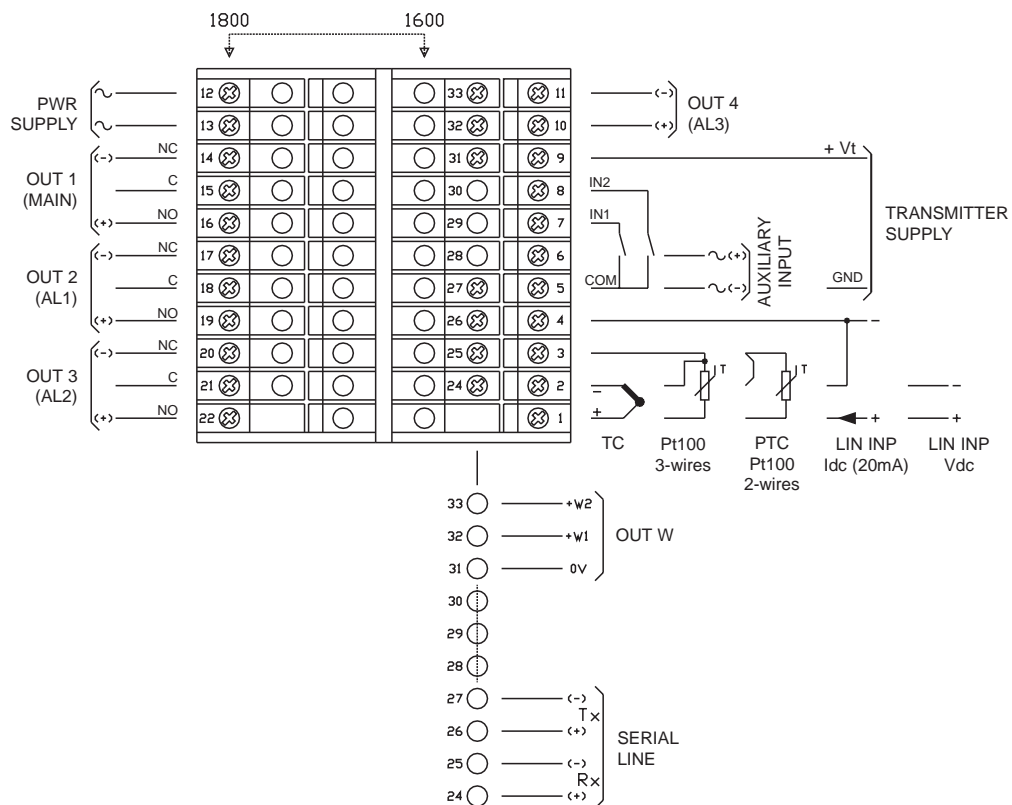

Apply users' manual warnings for a correct installation

## ORDER CODE

MODEL	
1600P	1600P
1800P	1800P

OUTPUTS 1,2,3,4 (R/D)	
Out1 (D) + Out2 (R) + Out3 (R)	DRR0
Out1 (D) + Out2 (R) + Out3 (R) + Out4 (R)	DRRR
Out1 (D) + Out2 (R) + Out3 (R) + Out4 (D)	DRRD
Out1 (R) + Out2 (R) + Out3 (R)	RRR0
Out1 (R) + Out2 (R) + Out3 (R) + Out4 (R)	RRRR
Out1 (R) + Out2 (R) + Out3 (R) + Out4 (D)	RRRD

OUTPUTS 5, 6	
None	00
OUT 5 (W1) 0...10V	V0
OUT 5 (W1) 0/4...20mA	I0
OUT 5 (W1) 0...10V OUT 6 (W2) 0...10V	VV
OUT 5 (W1) 0/4...20mA OUT 6 (W2) 0...10V	IV
OUT 5 (W1) 0/4...20mA OUT 6 (W2) 0/4...20mA	II

POWER SUPPLY	
0	20...27Vac/dc
1	100...240Vac/dc

DIGITAL COMMUNICATIONS	
0	None
2	RS 485 / RS 232





  

AUXILIARY INPUTS INSPR, INTA / LOGIC IN1, IN2 / TRANSMITTER SUPPLY	
00	None
01	IN1, IN2 NPN/PNP
03	Trasmitter Supply 10 V/24V
04	IN1, IN2 NPN/ PNP + Trasmitter Supply 10 V/24V
06	IN SPR (0...1V) + Trasmitter Supply 10 V/24V
07	IN SPR (0...10V) / IN Potentiometer # + Trasmitter Supply 10 V/24V
08	IN SPR (0/4...20mA) + Trasmitter Supply 10 V/24V
09	IN TA (5050mAac) + Trasmitter Supply 10 V/24V
10	IN1, IN2 NPN/PNP IN SPR (0...10V) + Trasmitter Supply 10V/24V
11	IN1, IN2 NPN/PNP IN SPR (0...10V) / IN Potentiometer # + Trasmitter Supply 10V / 24V
12	IN1, IN2 NPN/PNP IN SPR (0/4...20mA) + Trasmitter Supply 10V/24V
13	IN1, IN2 NPN/PNP IN TA (50mAac.a.) + Trasmitter Supply 10V/24V
33	IN SPR (0...1V)
34	IN SPR (0...10V) / Potentiometer #
35	IN SPR (0/4...20mA)
36	IN TA (50mAac)

# Potentiometer input requires 10V Trasmitter Supply  
Make specific calibration request for PTC input.

Please, contact GEFTRAN sales people for the codes availability.

GEFRAN spa reserves the right to make any kind of design or functional modification at any moment without prior notice.

	Conformity C/UL/US File no. E216851
	Conformity C/CSA/US Certificato n. 188658 - 1079784
	In conformity to ECC 89/336/CEE and 73/23/CEE with reference to standards: - EN 61000-6-2 (immunity in industrial environment) - EN 61000-6-3 (emission in residential environment) - EN 61010-1 (safety)
	C - TICK